

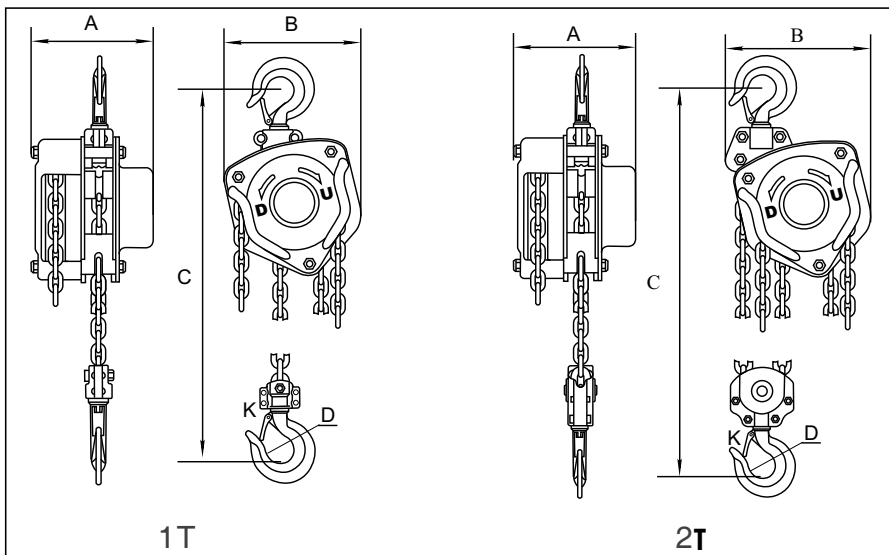

TOHO Chain Blocks Stainless Steel

Stainless steel chains blocks are required in many different industries where a sterile environment is required. It is suitable for food manufacturing, medical and pharmaceutical as well as marine / chemical industries and other highly corrosive environments.

- Light weight, easy to operate by worker.
- Treated by special anti-corrosion technology.
- Salt spray test over 1000 hours - will last 25 times longer than regular chain block.
- Test Certificate & Instruction Manual supplied with every Chain Block
- Industrial quality - complies with AS / NZS 1418.2
- Grade 50 stainless steel chain



Models	TCBSS1T3M	TCBSS1T6M	TCBSS2T3M	TCBSS2T6M	
Dimension (mm)	A	175	175	205	205
	B	210	210	255	255
	C	470	470	548	548
	D	50	50	55	55
	K	35	35	39	39
Nett Weight kg	19.5	26.7	32	41.6	
Pack size cm	29x20x21	38x25x21	29x20x21	38x25x21	
Extra weight per metre of extra lift	2.4	2.4	3.2	3.2	

Model	Size	Lift	Chain Size mm	No of Chains
TCBSS1T3M	1T	3m	7 x 21	1
TCBSS1T6M	1T	6m	7 x 21	1
TCBSS2T3M	2T	3m	7 x 21	2
TCBSS2T6M	2T	6m	7 x 21	2



Push Girder Trolley Stainless Steel

- Complies with AS/NZS 4991
- Test Certificate & Instruction Manual supplied with every Trolley
- Adjustable width: the wheels are made to fit any type of beam.
- Trolley can move smoothly on cast iron flanged because of the special design.

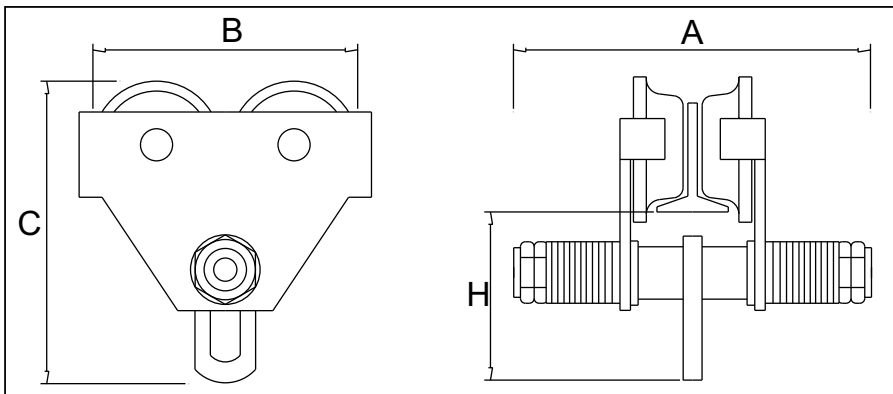

Models		GPTSS1T	GPTSS2T
Dimension (mm)	A	246	280
	B	239	270
	C	214	248
	H	120	145
Min. Turning radius m		1.0	1.1
Pack size cm		36x13x22	34x18x26
Flange width mm		64-203	88-203

Model	Size	Style	Beam
GPTSS1T	1T	Push	64-203mm
GPTSS2T	2T	Push	88-203mm